

4

3

2

1

D

D

C

C

B

B

A

A

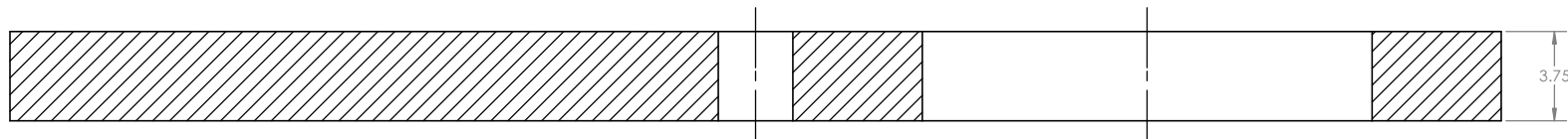
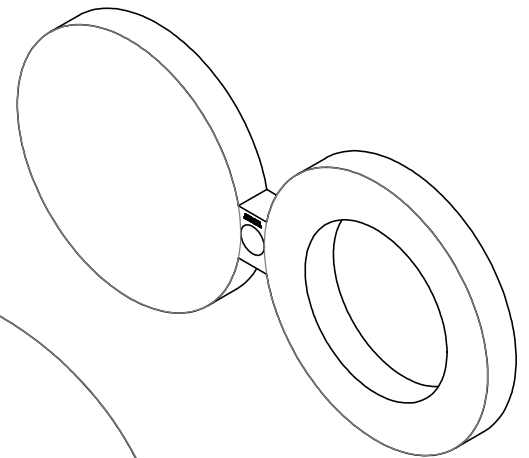
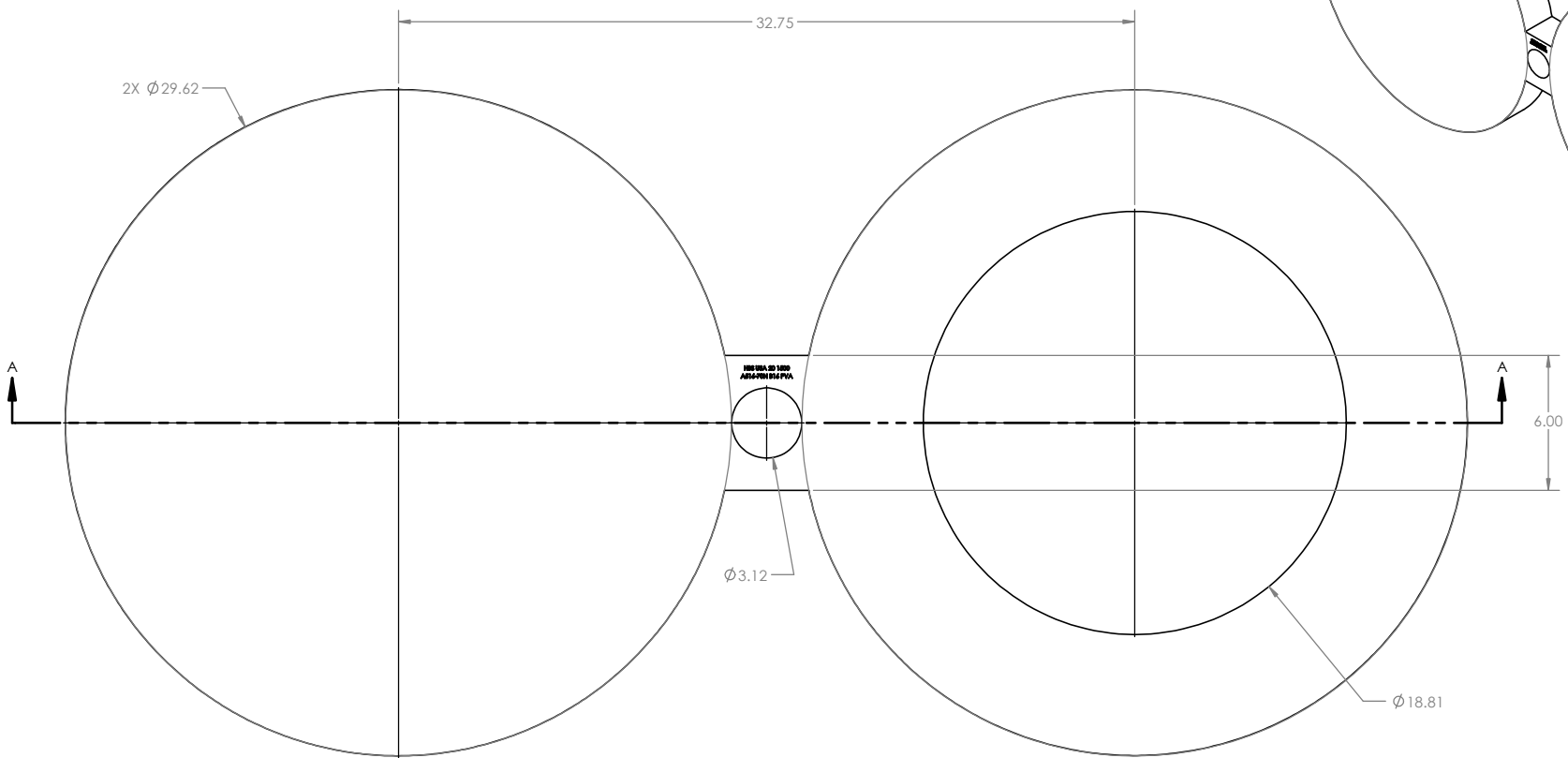

SECTION A-A

DO NOT SCALE PRINT		UNLESS OTHERWISE SPECIFIED: OUTSIDE DIAMETER: (+/-0.12) INSIDE DIAMETER: (+/-0.12) THICKNESS TOLERANCES (-ZERO +0.19) ALL UNITS IN INCHES OR POUNDS		HYDROBLIND -ISOLUTIONS
MATERIAL: CUSTOMER REQUESTED		SHEET 1 OF 1		
DATE: 07/06/2020		DIMENSIONS & TOLERANCES TO BE IN ACCORDANCE WITH ASME B16.48		DRAWING TITLE: 20 CL 1500 FIGURE 8 BLIND
SCALE 1:3	SIZE C	DRAWING NUMBER: FSBX		WEIGHT 1,170 lb
				REV 00

4

3

2

1